

Automatic and Semi-Automatic “EZ-Feed” Denester and Depalletizer Systems

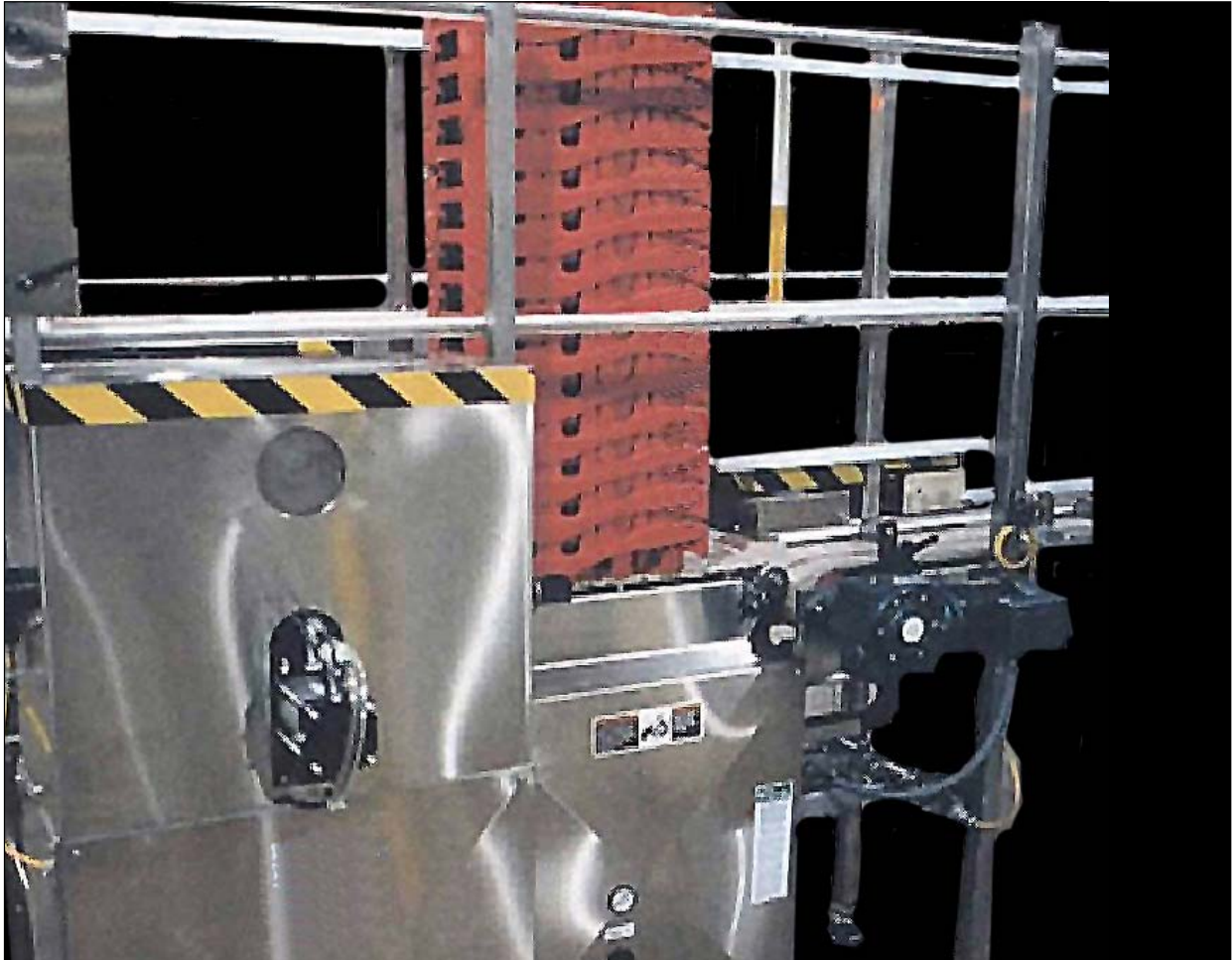

Denester Features:

- Two-stage “Grabber” belt system provides positive case separation
- Direct drive through a hollow shaft, foot-mounted gearbox and motor - no roller chains or sprockets to align or maintain
- Self-adjusting heads that require no changeover or only minor wrenchless adjustment for containers of different lengths
- Variable frequency drive allows for automatic speed adjustments through a wide range of case speeds
- Denester heads and conveyor constructed from stainless steel
- Secondary belts are adjustable both vertically and horizontally for precise positioning
- High-grip, long-lasting urethane grabber belts
- Pre-wired for rapid installation
- Wide variety of layout configurations available

Barry-Wehmiller

Automatic and Semi-Automatic ‘EZ-Feed’ Denester and Depalletizer Systems

Depalletizer Features:

- Automatic pallet and load separation
- Tough urethane bonded clamps
- Automatic pallet discharge and stacking
- Ability to run various containers and pallets without mechanical changes
- Fully pre-wired for ease of installation
- All pneumatic and electric operation



The ‘EZ-Feed’ Reusable Container Handling Systems are designed to totally eliminate or reduce the amount of manual labor required to return plastic cases to the production line.

We incorporate the latest technology along with sound and proven mechanical design to provide a low maintenance, operator friendly system, capable of running many different size containers with no changeover required for most container sizes.

Please contact our experienced teams at FleetwoodGoldcoWyard to discuss your special application(s).

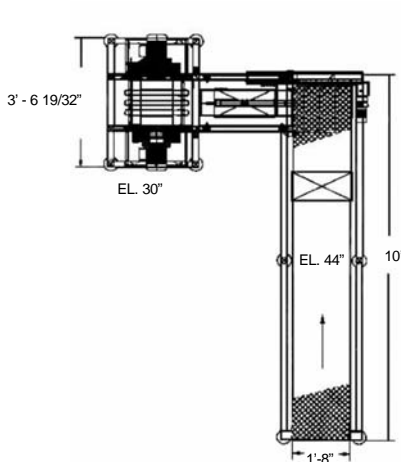

Original Right Angle Denester

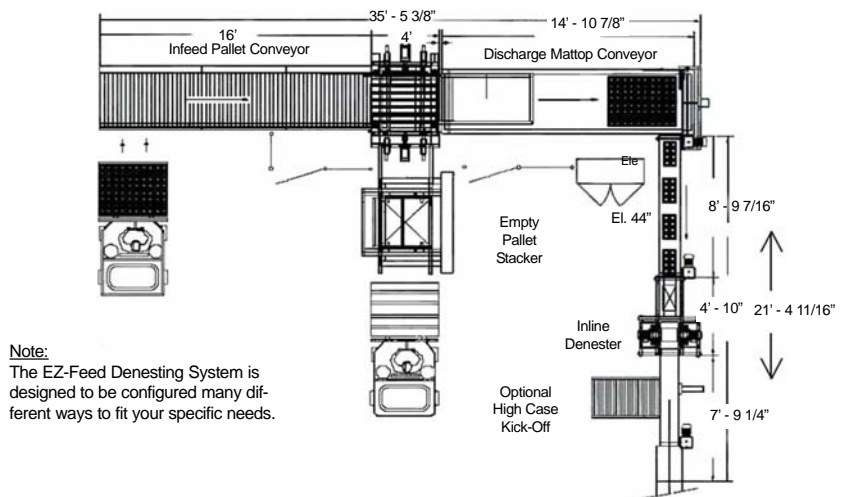

Note:
The EZ-Feed Denesting System is designed to be configured many different ways to fit your specific needs.

Automatic Returnable Shell Depalletizer/Denester System

FleetwoodGoldcoWyard **AMBEC**

1305 Lakeview Drive • Romeoville, IL 60446 • 630/759-6800

• *Loveland, CO*
970/663-4770

• *Lino Lakes, MN*
651/464-4000

• *St. Albans, England*
+44 1727 836101

• *Hunt Valley, MD*
410/785-1934

• *Lynchburg, VA*
434/582-1200

www.FGWA.com • sales@FGWA.com